

Grinding Machine - Standard

Unit 8 Willows Business Park Shelley Huddersfield
West Yorkshire England HD8 8LU
T. +44 (0)1484 600560 F. +44 (0)1484 600570
email: info@rollertech.co.uk

www.rollertech.co.uk

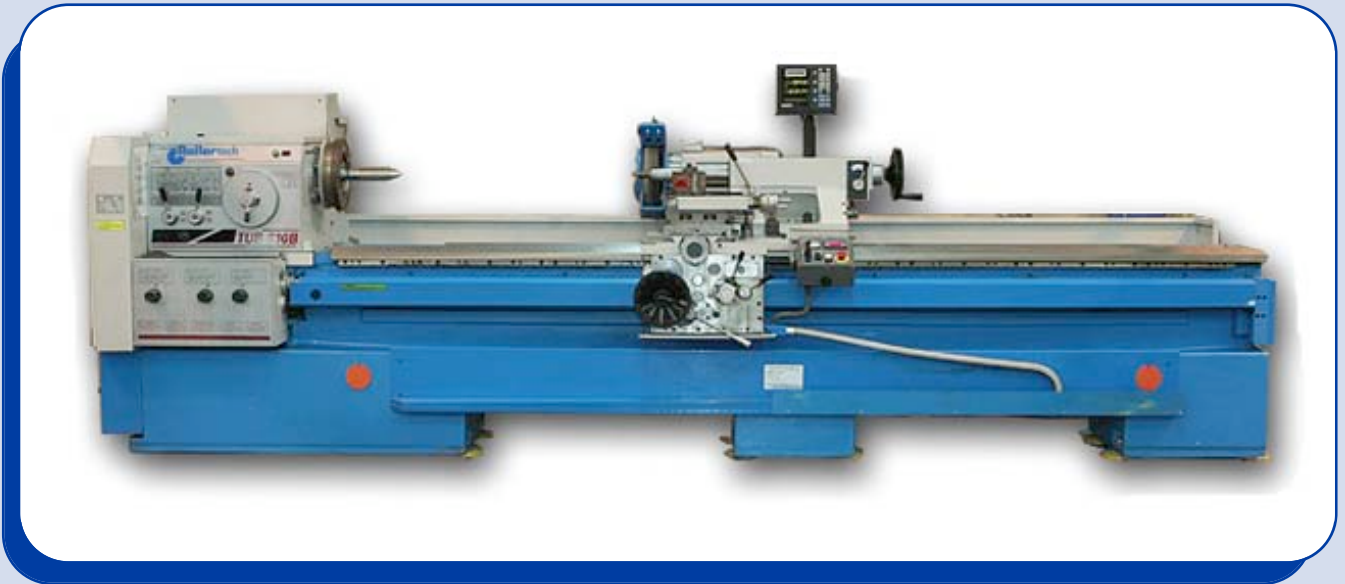

TUB630B fitted with DRO



Optional Wizard™ Crowning attachment



Travel & Spin settings

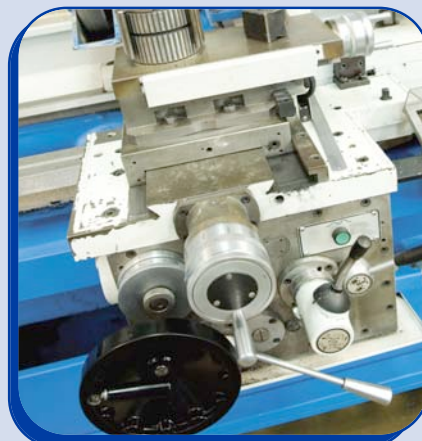

Operator Controls



Optional Carbide Grinding Wheel

Grinding Machine - Standard

Performance

- Specifically designed for the rubber roller industry.
- Reliable, strong, stable, accurate and efficient machines
- Extremely competitively priced
- Designed to optimise productivity

Technical Specification

Our standard grinding machines include the TUB630, TUB 730 and TUB830

Lengths available 2mtr, 3mtr, 4mtr

Diameter capacity, 380mm(TUB630), 480mm(TUB730), 580mm(TUB830)

Infinitely variable 11kw grinding motor

Upto 5800 rpm

Takes a 350mm x 60mm grinding wheel

Spindle speeds from 18-2000 rpm

Options

Colour specific to customer requirement

Digital display 2 axis x 3 axis

Three point steady

Tooling

Machine stops

Crowning attachment Wizard 3™ or 4™

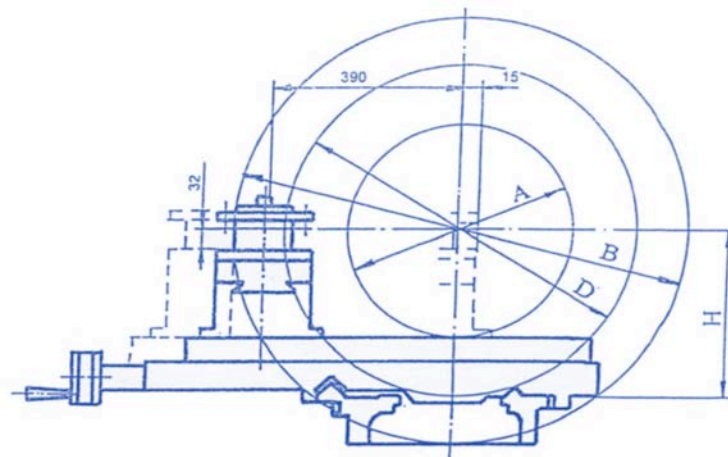

Model	A	B	D	H
TUB 630 B	380 mm	820 mm	660 mm	320 mm
TUB 730 B	480 mm	920 mm	750 mm	370 mm
TUB 830B	580 mm	1020 mm	850 mm	420 mm